

## PRODUCT SPECIFICATION

### GLSF-1503-80D(I)



---

#### 155Mb/s Duplex LC 1550nm DFB-LD 80Km SMF SFP Transceiver

#### ■ Features:

- ★ Up to 155Mb/s Data Links
- ★ Hot-Pluggable
- ★ 1550nm DFB laser transmitter
- ★ Duplex LC connector
- ★ Up to 80Km on 9/125μm SMF
- ★ Single +3.3V Power Supply
- ★ Monitoring Interface Compliant with SFF-8472
- ★ Low power dissipation <1.5W typically
- ★ Industrial /Extended/ Commercial operating temperature range: -40°C to 85°C/-5°C to 85°C/-0°C to 70°C Version available
- ★ RoHS compliant and Lead Free



#### ■ Applications:

- ★ Fast Ethernet
- ★ SONET OC-3/SDH STM-1
- ★ Other Optical Link

#### ■ Description:

GLight GLSF-1503-80D(I) Small Form Factor Pluggable (SFP) Transceiver is a high performance, cost effective module which has a Duplex LC optics interface, Standard AC coupled CML for high speed signal and LVTTTL control and monitor signals. The receiver section uses a PIN receiver and the transmitter uses 1550 nm DFB laser, up to 20dB link budget ensure this module SONET OC-3/SDH STM-1 80Km application.

## ■ Absolute Maximum Ratings

Parameter	Symbol	Min.	Typical	Max.	Unit
Case operating Temperature	Industrial	-40		+85	°C
	Extended				°C
	Commercial	0		70	°C
Supply Voltage	V <sub>CCT,R</sub>	-0.5		4	V
Relative Humidity	RH	0		85	%

## ■ Electrical Characteristics (T<sub>OP</sub> = T<sub>c</sub>, V<sub>CC</sub> = 3.135 to 3.465 Volts)

Parameter	Symbol	Min.	Typical	Max.	Unit	Note
Supply Voltage	V <sub>cc</sub>	3.14	3.3	3.47	V	
Supply Current	I <sub>cc</sub>			300	mA	
Inrush Current	I <sub>surge</sub>			I <sub>cc</sub> +30	mA	
Maximum Power	P <sub>max</sub>			1.0	mW	
<b>Transmitter Section:</b>						
Input differential impedance	R <sub>in</sub>	90	100	110		
Single ended data input swing	V <sub>in PP</sub>	200		1200	mVp-p	
Transmit Disable Voltage	V <sub>D</sub>	V <sub>cc</sub> – 1.3		V <sub>cc</sub>	V	2
Transmit Enable Voltage	V <sub>EN</sub>	V <sub>ee</sub>		V <sub>ee</sub> + 0.8	V	
Transmit Disable Assert Time	T <sub>dessert</sub>			10	us	
<b>Receiver Section:</b>						
Single ended data output swing	V <sub>out,pp</sub>	300	500	1000	mv	3
Data output rise time	t <sub>r</sub>			1300	ps	4
Data output fall time	t <sub>f</sub>			1300	ps	4
LOS Fault	V <sub>losfault</sub>	V <sub>cc</sub> – 0.5		V <sub>CC_host</sub>	V	5
LOS Normal	V <sub>los norm</sub>	V <sub>ee</sub>		V <sub>ee</sub> +0.5	V	5
Power Supply Rejection	PSR	100			mVpp	6
Deterministic Jitter Contribution	RXΔDJ			51.7	ps	7
Total Jitter Contribution	RXΔTJ	100			ps	

Note:

1. AC coupled.
2. Or open circuit.
3. Into 100 ohm differential termination.
4. 20 – 80 %
5. LOS is LVTTTL. Logic 0 indicates normal operation; logic 1 indicates no signal detected.
6. All transceiver specifications are compliant with a power supply sinusoidal modulation of 20 Hz to 1.5MHz up to specified value applied through the power supply filtering network shown on page 23 of the Small Form-factor Pluggable (SFP) Transceiver Multi-Source Agreement (MSA), September 14, 2000.

## ■ Optical Parameters( $T_{OP} = T_c$ , $VCC = 3.135$ to $3.465$ Volts)

Parameter	Symbol	Min.	Typical	Max.	Unit	Note
<b>Transmitter Section:</b>						
Center Wavelength	$\lambda_c$	1530	1550	1570	nm	1
Spectral Width(RMS)	$\sigma_{RMS}$			1	nm	
Optical Output Power	$P_{out}$	-5		0	dBm	2
Optical Rise/Fall Time	$t_r / t_f$			1300	ps	3
Extinction Ratio	ER	9			dB	
Relative Intensity Noise	RIN				dB/Hz	
Deterministic Jitter Contribution	TX $\Delta$ DJ				ps	
Total Jitter Contribution	TX $\Delta$ TJ				ps	
Eye Mask for Optical Output	Compliant with IEEE802.3 z (class 1 laser safety)					
<b>Receiver Section:</b>						
Optical Input Wavelength		1530		1570	nm	
Optical Input Power	$P_{in}$	-34		-3	dBm	4,5
Receiver Overload	$P_{ol}$	-8			dBm	4,5
RX Sensitivity	Sen			-32	dBm	4,5
Receiver Reflectance		12			dB	
RX_LOS Assert	LOS <sub>A</sub>	-42			dBm	
RX_LOS Deassert	LOS <sub>D</sub>			-34	dBm	
RX_LOS Hysteresis	LOS <sub>H</sub>		2	2.5	dB	
<b>General Specifications</b>						
Data Rate	BR		155		Mb/s	
Bit Error Rate	BER			$10^{-12}$		
Max. Supported Link Length on 9/125 $\mu$ m SMF@155M	L <sub>MAX</sub>		80		km	6
Total System Budget	LB	20			dB	7

### Note

1. Also specified to meet curves in FC-PI 13.0 Figures 18 and 19, which allow trade-off between wavelength spectral widths.
2. Class 1 Laser Safety per FDA/CDRH and EN (IEC) 60825 regulations.
3. Unfiltered, 20-80%. Complies with IEEE 802.3 (Gig. E), FC 1x and 2x eye masks when filtered.
4. Measured with conformance signals defined in FC-PI 13.0 specifications.
5. Measured with PRBS 231 -1at 10-12 BER
6. Dispersion limited per FC-PI Rev. 13
7. .Attenuation of 1dB/km is used for the link length calculations. Distances are indicative only. Please refer to the Optical Specifications in Table IV to calculate a more accurate link budget based on specific conditions in your application.

## Pin Assignment

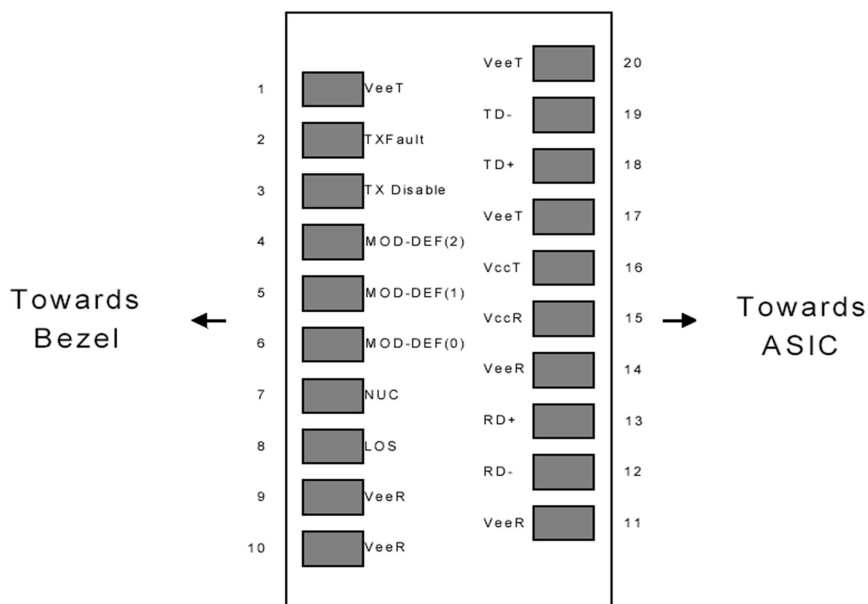

Diagram of Host Board Connector Block Pin Numbers and Names

## Pin Description

Pin No	Name	Function	Plug Seq	Notes
1	VeeT	Transmitter Ground	1	1
2	TX Fault	Transmitter Fault Indication	3	
3	TX Disable	Transmitter Disable	3	2
4	MOD-DEF2	Module Definition	2	3
5	MOD-DEF1	Module Definition 1	3	3
6	MOD-DEF0	Module Definition 0	3	3
7	Rate Select	Not Connected	3	4
8	LOS	Loss of Signal	3	5
9	VeeR	Receiver Ground	1	1
10	VeeR	Receiver Ground	1	1
11	VeeR	Receiver Ground		1
12	RD-	Inv. Received Data Out	3	6
13	RD+	Received Data Out	3	6
14	VeeR	Receiver Ground	3	1
15	VccR	Receiver Power	2	1
16	VccT	Transmitter Power	2	
17	VeeT	Transmitter Ground	1	
18	TD+	Transmit Data In	3	6
19	TD-	Inv. Transmit In	3	6
20	VeeT	Transmitter Ground	1	

**Notes:**

1. Circuit ground is internally isolated from chassis ground.
2. Laser output disabled on TDIS >2.0V or open, enabled on TDIS <0.8V.
3. Should be pulled up with 4.7k - 10 kohms on host board to a voltage between 2.0V and 3.6V. MOD\_DEF(0) pulls line low to indicate module is plugged in.
4. Rate select is not used
5. LOS is open collector output. Should be pulled up with 4.7k – 10 kohms on host board to a voltage between 2.0V and 3.6V. Logic 0 indicates normal operation; logic 1 indicates loss of signal.
6. AC Coupled

## ■ SFP Module EEPROM Information and Management

The SFP modules implement the 2-wire serial communication protocol as defined in the SFP -8472. The serial ID information of the SFP modules and Digital Diagnostic Monitor parameters can be accessed through the I<sup>2</sup>C interface at address A0h and A2h. The memory is mapped in Table 1. Detailed ID information (A0h) is listed in Table 2. And the DDM specification is at address A2h. For more details of the memory map and byte definitions, please refer to the SFF-8472, “Digital Diagnostic Monitoring Interface for Optical Transceivers”. The DDM parameters have been internally calibrated.

**Table 1.** Digital Diagnostic Memory Map (Specific Data Field Descriptions)

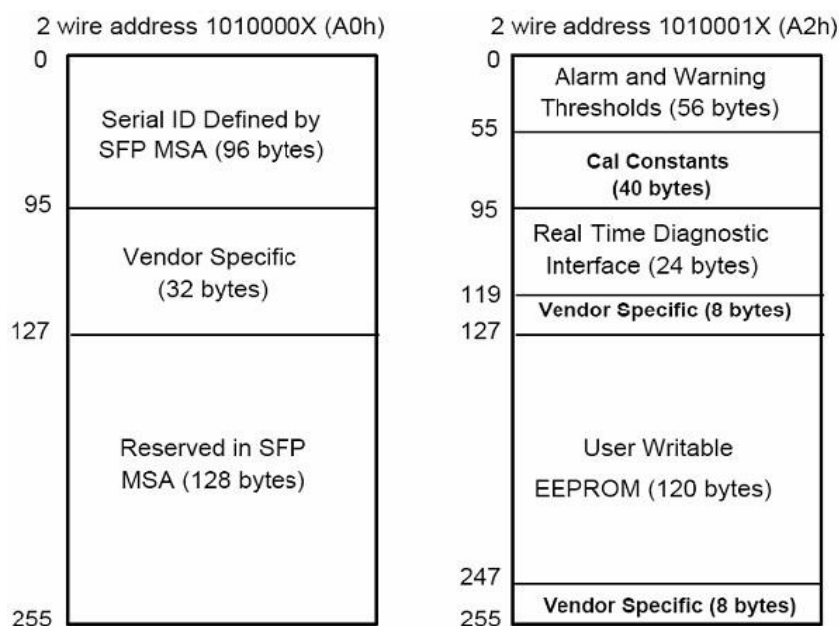

**Table 2.** EEPROM Serial ID Memory Contents(A0h)

Data Address	Length (Byte)	Name of Length	Description and Contents
Base ID Fields			
0	1	Identifier	Type of Serial transceiver (03h=SFP)
1	1	Reserved	Extended identifier of type serial transceiver (04h)
2	1	Connector	Code of optical connector type (07=LC)
3-10	8	Transceiver	SONET
11	1	Encoding	SONET Scrambled
12	1	BR,Nominal	Nominal baud rate, unit of 100Mbps
13	1	Reserved	(0000h)
14	1	Length(9um,km)	Link length supported for 9/125um fiber, units of km
15	1	Length(9um)	Link length supported for 9/125um fiber, units of 100m
16	1	Length(50um)	Link length supported for 50/125um fiber, units of 10m
17	1	Length(62.5um)	Link length supported for 62.5/125um fiber, units of 10m
18	1	Length(Copper)	Link length supported for copper, units of meters
19	1	Reserved	
20-35	16	Vendor Name	SFP vendor name:
36	1	Reserved	
37-39	3	Vendor OUI	SFP transceiver vendor OUI ID
40-55	16	Vendor PN	Part Number: "GL-xxxxx" (ASCII)
56-59	4	Vendor rev	Revision level for part number
60-61	2	Wavelength	Laser wavelength
62	1	Reserved	
63	1	CCID	Least significant byte of sum of data in address 0-62
Extended ID Fields			
64-65	2	Option	Indicates which optical SFP signals are implemented(001Ah = LOS, TX_FAULT, TX_DISABLE all supported)
66	1	BR, max	Upper bit rate margin, units of %
67	1	BR, min	Lower bit rate margin, units of %
68-83	16	Vendor SN	Serial number (ASCII)
84-91	8	Date code	Manufacturing date code
92	1	Diagnostic Type	Diagnostics
93	1	Enhanced Options	Diagnostics
94	1	SFF-8472	Diagnostics
95	1	CCEX	Check code for the extended ID Fields (addresses 64 to 94)
Vendor Specific ID Fields			
96-127	32	Readable	Vendor specific date, read only
128-255	128	Reserved	Reserved for SFF-8079

## Digital Diagnostic Monitor Characteristics

Data Address	Parameter	Accuracy	Unit	Calibraton
96-97	Transceiver Internal Temperature	±3.0	°C	internal
98-99	VCC3 Internal Supply Voltage	±5.0	%	internal
100-101	Laser Bias Current	±10	%	internal
102-103	Tx Output Power	±3.0	dBm	internal
104-105	Rx Input Power	±3.0	dBm	internal

## Regulatory Compliance

The transceiver complies with international Electromagnetic Compatibility (EMC) and international safety requirements and standards (see details in Table following).

Electrostatic Discharge (ESD) to the Electrical Pins	MIL-STD-883E Method 3015.7	Class 1(>1000 V)
Electrostatic Discharge (ESD) to the Duplex LC Receptacle	IEC 61000-4-2 GR-1089-CORE	Compatible with standards
Electromagnetic Interference (EMI)	FCC Part 15 Class B EN55022 Class B (CISPR 22B) VCCI Class B	Compatible with standards
Laser Eye Safety	FDA 21CFR 1040.10 and 1040.11 EN60950, EN (IEC) 60825-1,2	Compatible with Class 1 laser product.

## Recommended circuit & Mechanical Dimensions

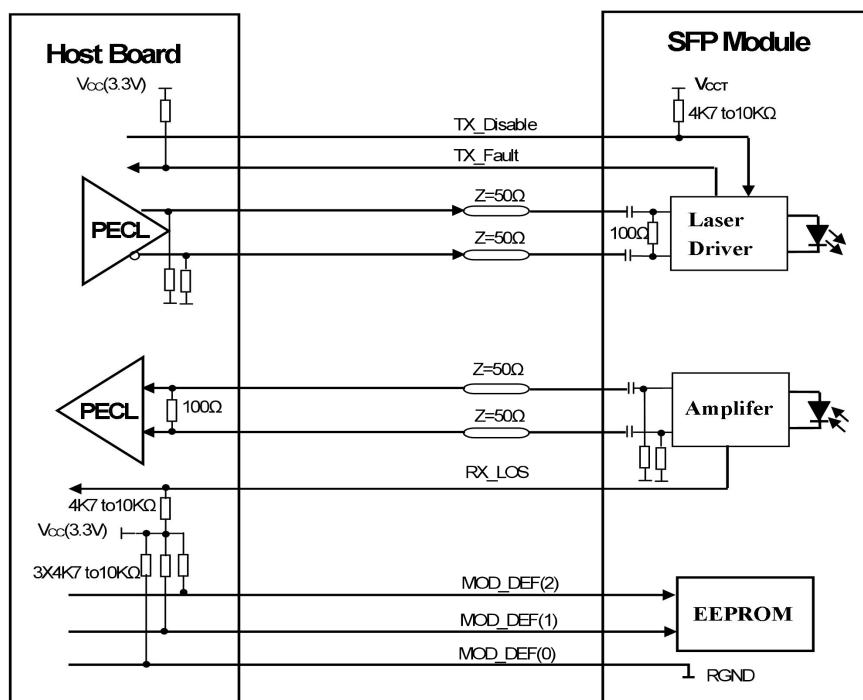

SFP Host Recommended Circuit

## ■ Mechanical Dimensions

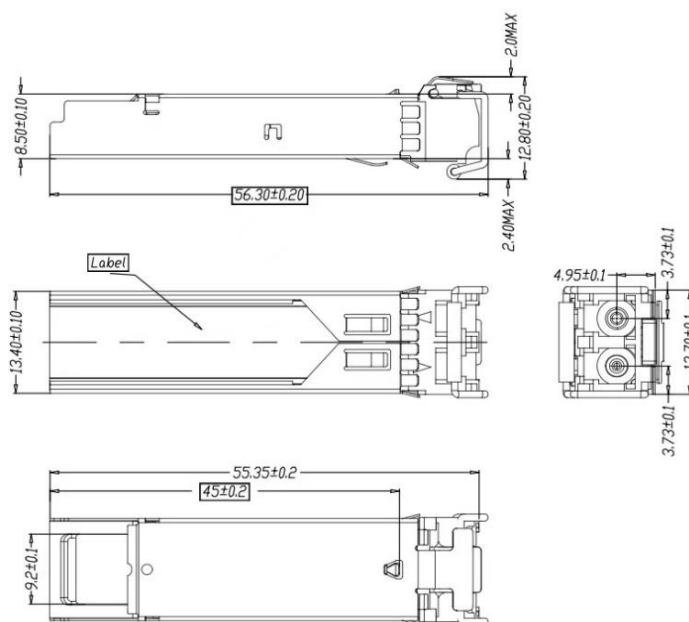

**Mechanical Drawing**

### Shenzhen GLight Communication Technology Co., Ltd.

Building 3, ChaoHuiLou Technology Industrial Park, No.119 Huating Road,  
Dalang Sub-district, Longhua District, Shenzhen, China

GLIGHT reserves the right to make changes to the products or information contained herein without notice.

No liability is assumed as a result of their use or application.

No rights under any patent accompany the sale of any such products or information.

Published by Shenzhen GLight Communication Technology Co., Ltd. Copyright © GLight Communication Technology Co., Ltd. All Rights Reserved.