

PRODUCT SPECIFICATION



GLXP-BL3296-40D(I)

10Gb/s BiDi Single LC, SMF, 13300nm/1270nm DFB/PIN, 40km SFP+ Transceiver

■ Features:

- ★ Support 8.5Gb/s to 11.3Gb/s
- ★ Hot-Pluggable SFP+ footprint
- ★ Single LC for Bi-directional Transmission
- ★ Built-in 1330nm DFB Laser.
- ★ Built-in 1270nm WDM Filter
- ★ Built-in digital diagnostic functions
- ★ Up to 40 km on 9/125µm SMF
- ★ Single +3.3V Power Supply
- ★ Low power dissipation <1.5W typically
- ★ No Reference Clock required
- ★ Industrial /Extended/ Commercial operating temperature range: -40°C to 85°C/-5°C to 85°C/-0°C to 70°C Version available
- ★ Very low EMI and excellent ESD protection
- ★ RoHS compliant



■ Applications:

- ★ 10GBASE-LR/LW Ethernet
- ★ 10G Fibre Channel
- ★ SONET OC-192/SDH STM-64

■ Description:

GLight GLXP-BL3296-40D(I) Bi-directional 10 GB/s (SFP+) transceivers are compliant with the current SFP+ Multi-Source Agreement (MSA) Specification. They comply with 10GBASE-BX/LR/LW Ethernet, SONET OC-192/SDH STM-64 and 10G Fibre Channel 1200-SM-LL-L. Digital diagnostics functions are available via a 2-wire serial interface, as specified in the SFP+ MSA.

■ Absolute Maximum Ratings

Parameter	Symbol	Min.	Typical	Max.	Unit
Storage Temperature	T _s	-40		+85	°C
Supply Voltage	V _{CC}	-0.5		4	V
Relative Humidity	RH	0		85	%

■ Recommended Operating Environment:

Parameter	Symbol	Min.	Typical	Max.	Unit
Case operating Temperature	T _c	-40		85	°C
		0		70	
Supply Voltage	V _{CC(T/R)}	3.14	3.3	3.47	V
Supply Current	I _{CC}			3500	mA
Power Dissipation	P _D			1.5	W

■ Electrical Characteristics (T_{OP} = T_c, V_{CC} = 3.135 to 3.465 Volts)

Parameter	Symbol	Min	Typ	Max	Unit	Note	
Transmitter:							
Differential input voltage swing		180		700	mVpp	1	
Transmit Disable Input	H	V _{IHH}	2.0		V _{CC} +0.3	V	
	L	V _{IL}	0		0.8	V	
Transmit Enable Output	H	V _{OH}	2.4		V _{CC} +0.3	V	
	L	V _{OL}	0		0.4	V	2
Input Differential Impedance	Z _{in}	80	100	120	Ω		
Receiver							
Differential output voltage swing		300		850	mVpp	3	
LOS Output	H	V _{OH}	2.4		V _{CC} +0.3	V	2
	L	V _{OL}	0		0.4	V	
Output Differential Impedance	Z _{on}	80	100	120	Ω		

Note:

1. TD+/- are internally AC coupled with 100Ω differential termination inside the module.
2. Tx Fault and Rx LOS are open collector outputs, which should be pulled up with 4.7k to 10kΩ resistors on the host board. Pull up voltage between 2.0V and V_{CC}+0.3V.
3. RD+/- outputs are internally AC coupled, and should be terminated with 100Ω (differential) at the user SERDES.

Optical Parameters($T_{OP} = T_c$, $VCC = 3.135$ to 3.465 Volts)

Parameter	Symbol	Min	Typ	Max	Unit	Ref.
Transmitter						
Date Rate		9.9		11.3	Gb/s	
Optical Wavelength	λ	1310	1330	1350	nm	
Average output power	P_o	0		5	dBm	
Optical Extinction Ratio	ER	3.5			dB	
RMS spectral width	$\Delta\lambda$			1	nm	
Side Mode Suppression Ratio	SMSR	30			dB	
Dispersion penalty				3.2	dB	
Optical Eye Mask		Compliant with IEEE802.3ae				
Receiver						
Date Rate		9.9		11.3	Gb/s	
Optical Wavelength	λ	1250	1270	1290	nm	
Receiver Sensitivity@10G	R			-15	dBm	1
Maximum Input Power	P _{MAX}	0			dBm	
LOS De-Assert	LOSD			-16	dBm	
LOS Assert	LOSA	-30			dBm	
LOS Hysteresis	0.5	2	2.5	4	dB	
Receiver Reflectance				-12	dB	
Overload	Sat	0.5			dBm	5

Note:

1. Measured with a PRBS of $2^{31}-1$ at 1×10^{-12} BER and 5 dB extinction ratio.

Pin Assignment

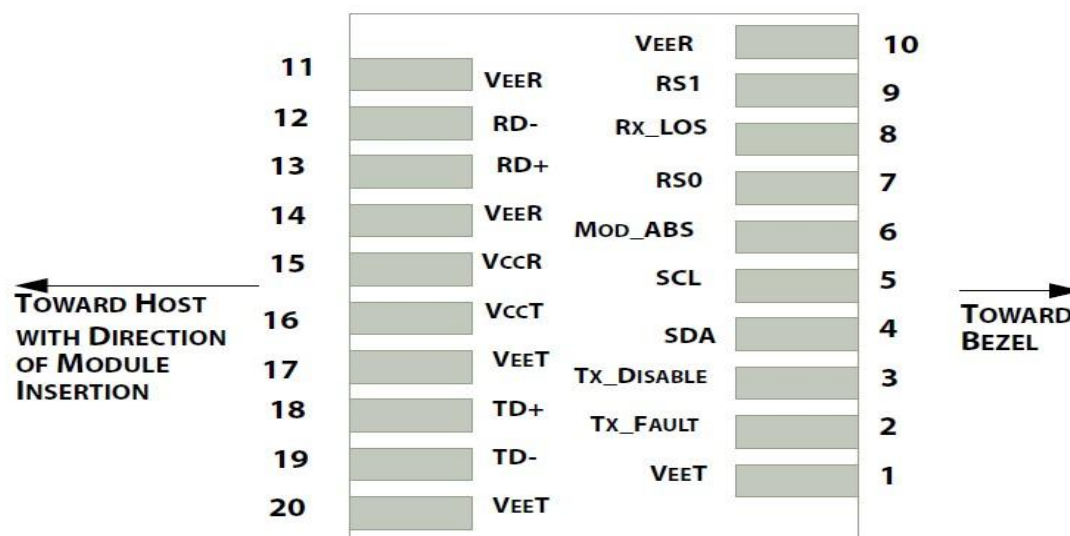

Diagram of Host Board Connector Block Pin Numbers and Names

■ Pin Description

Pin No	Name	Function	Notes
1	VeeT	Transmitter Ground	1
2	TX Fault	Transmitter Fault Indication	2
3	TX Disable	Transmitter Disable	3
4	SDL	2 wire serial interface data input/output (SDA)	
5	SCL	2 wire serial interface clock input (SCL)	
6	MOD-ABS	Module Absent, connect to VeeR or VeeT in the module	2
7	RS0	Rate select0, optionally control SFP+ receiver. When high, input data rate >4.5Gb/ s; when low, input data rate <=4.5Gb/s	
8	LOS	Loss of Signal	4
9	RS1	Rate select0, optionally control SFP+ transmitter. When high, input data rate >4.5Gb/s; when low, input data rate <=4.5Gb/s	
10	VeeR	Receiver Ground	1
11	VeeR	Receiver Ground	1
12	RD-	Inv. Received Data Out	
13	RD+	Received Data Out	
14	VeeR	Receiver Ground	1
15	VccR	Receiver Power	
16	VccT	Transmitter Power	
17	VeeT	Transmitter Ground	1
18	TD+	Transmit Data In	
19	TD-	Inv. Transmit In	
20	VeeT	Transmitter Ground	1

Notes:

1. The module ground pins shall be isolated from the module case.
2. This pin is an open collector/drain output pin and shall be pulled up with 4.7K-10Kohms to Host_Vcc on the host board.
3. This pin shall be pulled up with 4.7K-10Kohms to VccT in the module.
4. This pin is an open collector/drain output pin and shall be pulled up with 4.7K-10Kohms to Host_Vcc on the host board.

SFP Module EEPROM Information and Management

The SFP modules implement the 2-wire serial communication protocol as defined in the SFP-8472. The serial ID information of the SFP modules and Digital Diagnostic Monitor parameters can be accessed through the I²C interface at address A0h and A2h. The memory is mapped in Table 1. Detailed ID information (A0h) is listed in Table 2. And the DDM specification is at address A2h. For more details of the memory map and byte definitions, please refer to the SFF-8472, “Digital Diagnostic Monitoring Interface for Optical Transceivers”. The DDM parameters have been internally calibrated.

Table 1. Digital Diagnostic Memory Map (Specific Data Field Descriptions)

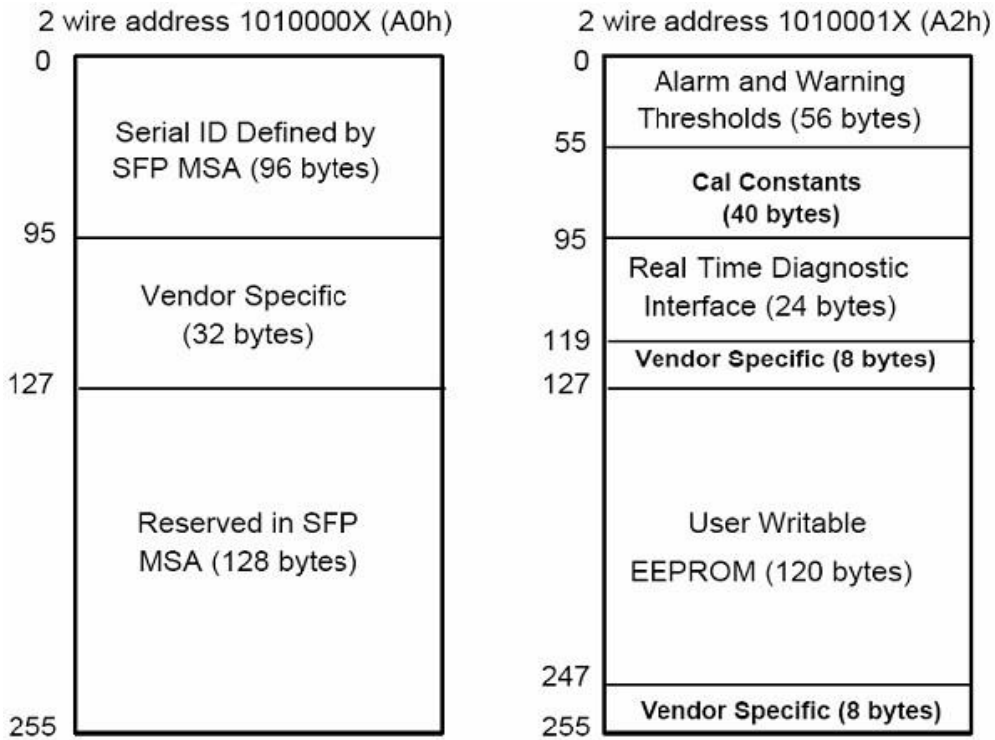

Table 2 - EEPROM Serial ID Memory Contents (A0h)

Data Address	Length (Byte)	Name of Length	Description and Contents
Base ID Fields			
0	1	Identifier	Type of Serial transceiver (03h=SFP)
1	1	Reserved	Extended identifier of type serial transceiver (04h)
2	1	Connector	Code of optical connector type (07=LC)
3-10	8	Transceiver	
11	1	Encoding	64B/66B
12	1	BR,Nominal	Nominal baud rate, unit of 100Mbps
13	1	Reserved	(0000h)
14	1	Length(9um,km)	Link length supported for 9/125um fiber, units of km
15	1	Length(9um)	Link length supported for 9/125um fiber, units of 100m
16	1	Length(50um)	Link length supported for 50/125um fiber, units of 10m
17	1	Length(62.5um)	Link length supported for 62.5/125um fiber, units of 10m
18	1	Length(Copper)	Link length supported for copper, units of meters
19	1	Reserved	
20-35	16	Vendor Name	SFP vendor name:
36	1	Reserved	
37-39	3	Vendor OUI	SFP transceiver vendor OUI ID
40-55	16	Vendor PN	Part Number: "xxxxxxx" (ASCII)
56-59	4	Vendor rev	Revision level for part number
60-61	2	Wavelength	Laser wavelength
62	1	Reserved	
63	1	CCID	Least significant byte of sum of data in address 0-62
Extended ID Fields			
64-65	2	Option	Indicates which optical SFP signals are implemented(001Ah = LOS, TX_FAULT, TX_DISABLE all supported)
66	1	BR, max	Upper bit rate margin, units of %
67	1	BR, min	Lower bit rate margin, units of %
68-83	16	Vendor SN	Serial number (ASCII)
84-91	8	Date code	Manufacturing date code
92	1	Diagnostic Type	Diagnostics
93	1	Enhanced Options	Diagnostics
94	1	SFF-8472	Diagnostics
95	1	CCEX	Check code for the extended ID Fields (addresses 64 to 94)
Vendor Specific ID Fields			
96-127	32	Readable	Vendor specific date, read only
128-255	128	Reserved	Reserved for SFF-8079

Digital Diagnostic Monitor Characteristics

Data Address	Parameter	Accuracy	Unit	Calibraton
96-97	Transceiver Internal Temperature	±3.0	°C	internal
98-99	VCC3 Internal Supply Voltage	±5.0	%	internal
100-101	Laser Bias Current	±10	%	internal
102-103	Tx Output Power	±3.0	dBm	internal
104-105	Rx Input Power	±3.0	dBm	internal

Regulatory Compliance

The transceiver complies with international Electromagnetic Compatibility (EMC) and international safety requirements and standards (see details in Table following).

Electrostatic Discharge (ESD) to the Electrical Pins	MIL-STD-883E Method 3015.7	Class 1(>1000 V)
Electrostatic Discharge (ESD) to the Duplex LC Receptacle	IEC 61000-4-2 GR-1089-CORE	Compatible with standards
Electromagnetic Interference (EMI)	FCC Part 15 Class B EN55022 Class B (CISPR 22B) VCCI Class B	Compatible with standards
Laser Eye Safety	FDA 21CFR 1040.10 and 1040.11 EN60950, EN (IEC) 60825-1,2	Compatible with Class 1 laser product.

Recommended Circuit:

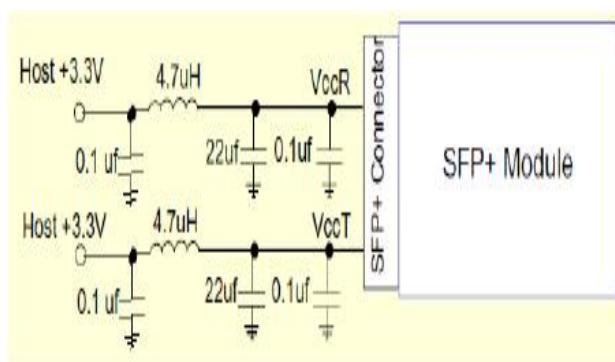

Recommended Host Board Power Supply Circuit

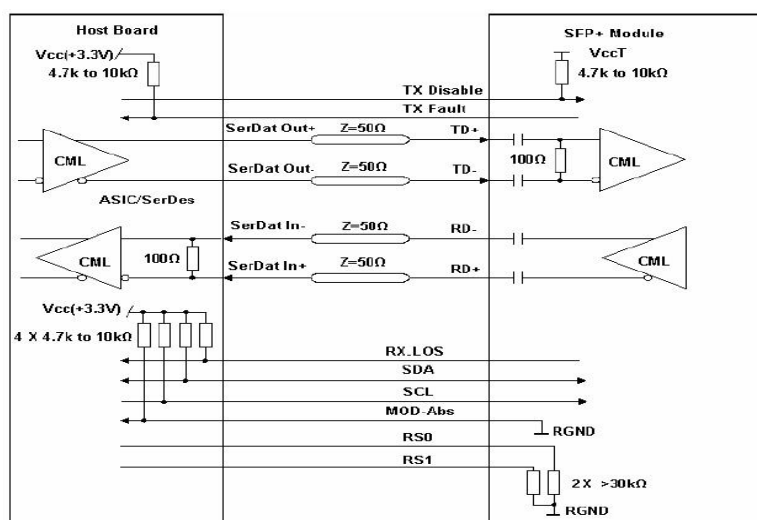

Recommended High-speed Interface Circuit

■ Mechanical Dimensions

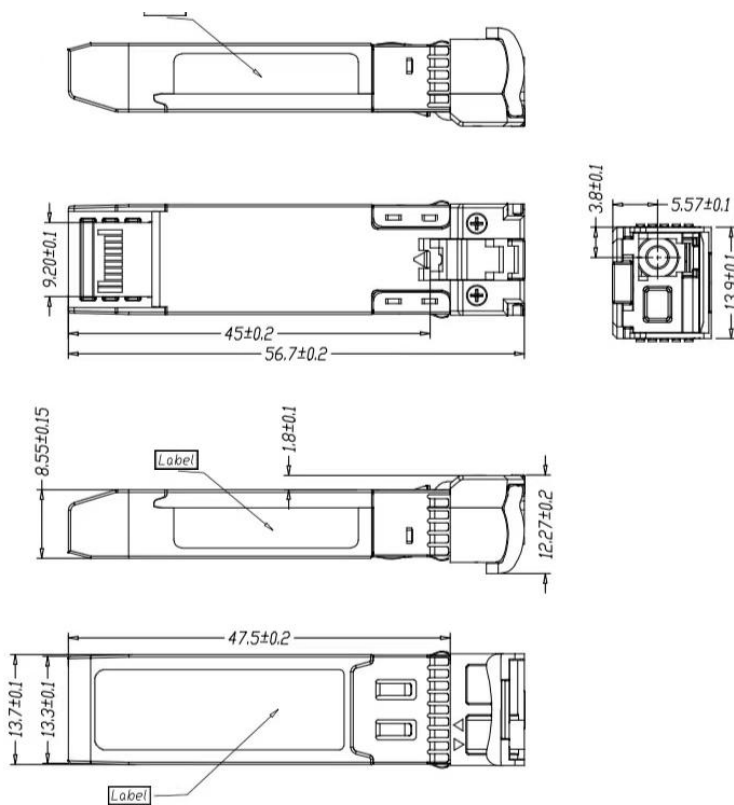

Mechanical Drawing

Shenzhen GLight Communication Technology Co., Ltd.

Building 3, ChaoHuiLou Technology Industrial Park, No.119 Huating Road,
Dalang Sub-district, Longhua District, Shenzhen, China

GLIGHT reserves the right to make changes to the products or information contained herein without notice.
No liability is assumed as a result of their use or application.
No rights under any patent accompany the sale of any such products or information.

Published by Shenzhen GLight Communication Technology Co., Ltd. Copyright © GLight Communication Technology Co., Ltd. All Rights Reserved.