

# PRODUCT SPECIFICATION



## GQXP-85B4-02D(I)

### 100G SR4 850nm MMF QSFP28 Optical Transceiver

#### ■ Features:

- ★ Hot-pluggable QSFP28 form factor
- ★ Supports 103.1Gb/s aggregate bit rate
- ★ Power dissipation < 2.5W
- ★ RoHS-6 compliant
- ★ Commercial case temperature range of 0°C to 70°C
- ★ Single 3.3V power supply
- ★ Maximum link length of 100m on OM4 Multimode Fiber (MMF)
- ★ 4x25Gb/s 850nm VCSEL-based transmitter
- ★ 4x25G electrical interface
- ★ Single MPO12 receptacle
- ★ I2C management interface



#### ■ Applications:

- ★ 100GBASE-SR4 100G Ethernet

#### ■ Description:

GLight GQXP-85B4-02D(I) 100G QSFP28 transceiver modules are designed for use in 100 Gigabit Ethernet links over multimode fiber. They are compliant with the QSFP28 MSA and IEEE 802.3bm 100GBASE-SR4 and CAUI-4. Digital diagnostics functions are available via the I2C interface, as specified by the QSFP28 MSA. The transceiver is RoHS-6 compliant per Directive 2011/65/EU.

## ■ Absolute Maximum Ratings

Parameter	Symbol	Min.	Typical	Max.	Unit
Storage Temperature	T <sub>S</sub>	-40		+85	°C
Case Operating Temperature	T <sub>A</sub>	0		70	°C
Supply Voltage	V <sub>CC</sub>	-0.5		4	V
Relative Humidity	RH	0		85	%
Receiver Damage Threshold, per Lane	P <sub>Rdmg</sub>	3.4			dBm
Industrial	TC	-40		85	°C
Commercial	TC	0		70	°C

## ■ Electrical Characteristics (EOL, TOP = 0 to 70C, V<sub>CC</sub> = 3.135 to 3.465 Volts)

Parameter	Symbol	Min.	Typical	Max.	Unit	Note
Supply Voltage	V <sub>CC</sub>	3.14		3.47	V	
Supply Current	I <sub>CC</sub>			600	mA	
Module total power	P			2.5	W	
<b>Transmitter Section:</b>						
Signaling rate per lane		25.78125 ± 100ppm			Gb/s	
Differential pk-pk input voltage tolerance	V <sub>in,pp,diff</sub>			900	mV	
Single-ended voltage tolerance	V <sub>in,pp</sub>	-0.35		+3.3	V	
Module stress input test		Per Section 83E.3.4.1, IEEE 802.3bm			V	
<b>Receiver Section:</b>						
Signaling rate per lane		25.78125 ± 100ppm			V	
Differential data output swing	V <sub>out,pp</sub>	100		400	mV <sub>pp</sub>	
		300		600		
		400	600	800		
		600		1200		
Eye width		0.57			UI	
Eye height, differential		228			mV	
Vertical eye closure	VEC	5.5			dB	
Transition time (20% to 80%)	t <sub>r</sub> , t <sub>f</sub>	12			ps	

## ■ Optical Characteristics (EOL, TOP = 0 to 70C, V<sub>CC</sub> = 3.135 to 3.465 Volts)

Parameter	Symbol	Min.	Typical	Max.	Unit	Note
<b>Transmitter Section:</b>						
Signaling Speed per Lane		25.78125 ± 100ppm			Gb/s	1
Center Wavelength	$\lambda_t$	830	850	870	nm	
RMS spectral width	$\Delta\lambda$			0.6	nm	
Average Optical Power per Lane	TXP <sub>x</sub>	-8.4		2.4	dBm	
Optical Power OMA per Lane	TxOMA	-6.4		3	dBm	
Launch Power [OMA] minus TDEC per Lane	P-TDEC	-7.3			dBm	
TDEC per Lane	TDEC			4.3	dBm	
Optical Extinction Ratio	ER	3.5			dB	
Optical Return Loss Tolerance	ORL			12	dB	
Encircled Flux	FLX	>86% at 19 $\mu$ m <30% at 4.5 $\mu$ m			dB	
Average Launch Power of OFF Transmitter, per Lane				-30	dBm	
Transmitter Eye mask definition {X1, X2, X3, Y1, Y2, Y3}		{0.3,0.38,0.45,0.35,0.41,0.5}				2
<b>Receiver Section:</b>						
Signaling Speed per Lane		25.78125 ± 100ppm			Gb/s	3
Center Wavelength	$\lambda_r$	840		860	nm	
Damage Threshold	DT	3.4			dBm	
Average Receive Power per Lane	RXP <sub>x</sub>	-10.3		2.4	dBm	
Receive Power (OMA) per Lane	RxOMA			3	dBm	
Receiver Reflectance	R <sub>fl</sub>			-12	dB	
Stressed Sensitivity (OMA)	SRS			-8.5	dBm	4
<b>Stressed Conditions:</b>						
Stressed Eye Closure	SEC	4.3			dB	
Stressed Eye J2 Jitter	J2	0.39			UI	
Stressed Eye J4 Jitter	J4	0.53			UI	
OMA of each aggressor lane		3			dBm	
Stressed Receiver Eye Mask Definition {X1, X2, X3, Y1, Y2, Y3}		{0.28,0.5,0.5,0.33,0.33,0.4}				5
Los De-Assert	LOS <sub>D</sub>			-12	dBm	
Los Assert	LOS <sub>A</sub>	-22			dBm	
Los Hysteresis	LOS <sub>H</sub>	0.5	2	2.5	dB	
Overload		2.4			dBm	

**Note:**

1. Transmitter consists of 4 lasers operating at a maximum speed of 25.78125Gb/s  $\pm$  100ppm each.
2. Hit Ratio  $1.5 \times 10^{-3}$  hits/sample.
3. Receiver consists of 4 photo detectors operating at a maximum speed of 25.78125Gb/s  $\pm$  100ppm each.
4. Minimum value is informative only and not the principal indicator of signal strength.
5. Hit Ratio  $5 \times 10^{-5}$  hits/sample

## ■ General Specifications

Parameter	Symbol	Min.	Typical	Max.	Unit
Bit Rate (all wavelengths combined)	BR			103.1	Gb/s
Bit Error Ratio (pre-FEC)	BER			$5 \times 10^{-5}$	
<b>Maximum Supported Distances</b>					
Fiber Type					
OM3 MMF	Lmax1			70	m
OM4 MMF	Lmax2			100	m

## ■ Pin Assignment:

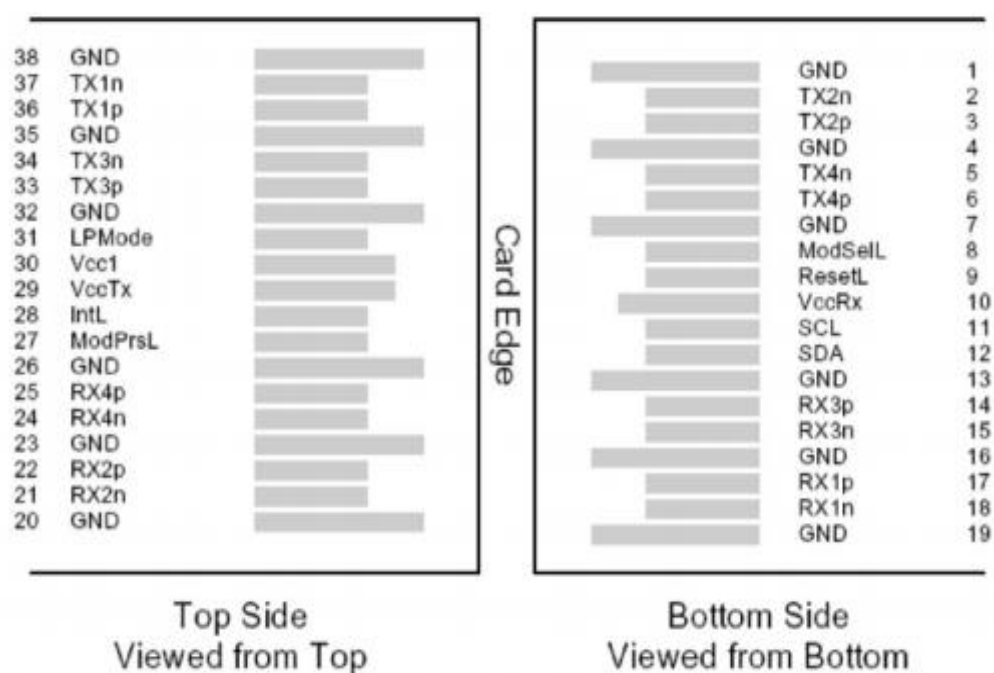

## ■ Digital Diagnostics Functions

The QSFP28 transceivers support the I2C-based diagnostics interface specified by the QSFP28 MSA.

## ■ Memory Contents

Per the QSFP28 MSA.

## ■ Mechanical Specifications

Per the QSFP28 MSA.

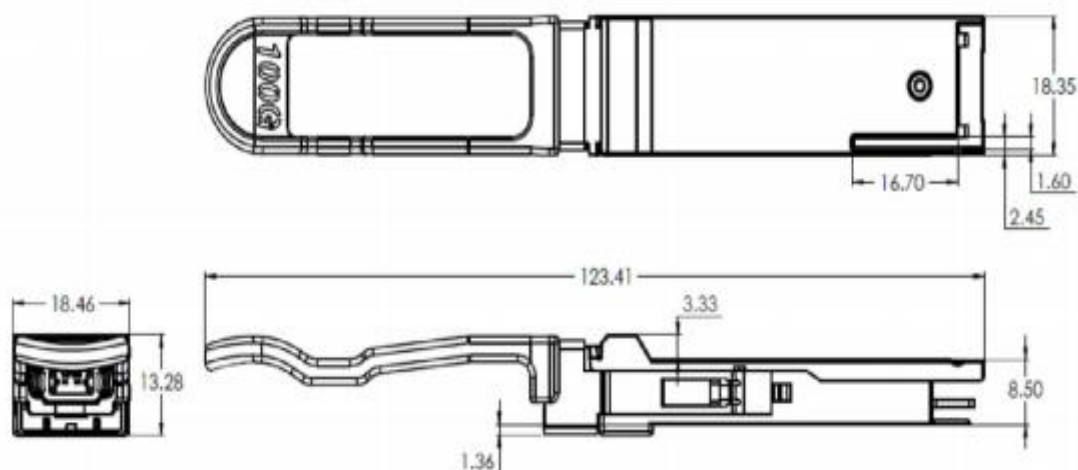

Mechanical Dimensions

## Shenzhen GLight Communication Technology Co., Ltd.

Building 3, ChaoHuiLou Technology Industrial Park, No.119 Huating Road,  
Dalang Sub-district, Longhua District, Shenzhen, China

GLIGHT reserves the right to make changes to the products or information contained herein without notice.  
No liability is assumed as a result of their use or application.  
No rights under any patent accompany the sale of any such products or information.

Published by Shenzhen GLight Communication Technology Co., Ltd. Copyright © GLight Communication Technology Co., Ltd. All Rights Reserved.